

Zero air loss

AUTOMATIC DRAIN



- Simple
- Reliable
- No Power
- Easy to Fix
- No Air Loss
- Non Corrosive
- Life Long Service
- Mechanical Float
- Easy Maintenance
- Suitable for any Industry
- Resistance to High Temperature
- No external Air Equaliser required
- Convenient ½" BSP(F) Connection
- Maximum Operating pressure 20 bar



Dimensions

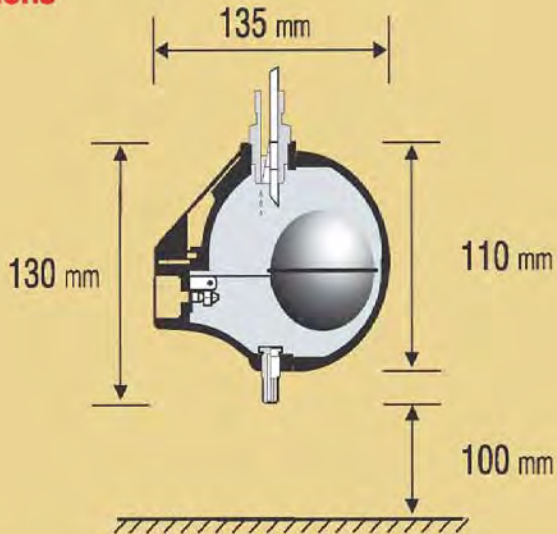

For effective removal of Condensate from:

- Filters
- Separators
- Receivers
- Ref. Dryers
- After Coolers
- Inter Coolers
- Droplegs, etc.

Working Principle

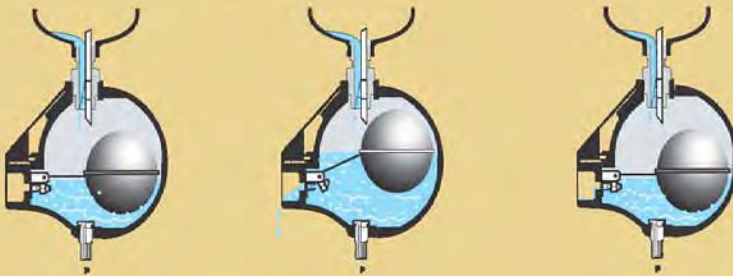

Material of Construction

Housing	: Aluminium
Float	: Stainless steel
Lever	: Stainless Steel
Manual Drain	: Brass

Technical Data	HAD-20B
Operating temperature range	Up to 100 °C
Operating pressure	20 bar
Mass	0,5 kg
Drain Capacity	400 l/hour
Inlet connection	G1/2"
Outlet connection	G1/2"
Dimension A x B x C	135 x 110 x 130 mm
Medium	Condensate (air, water, oil)

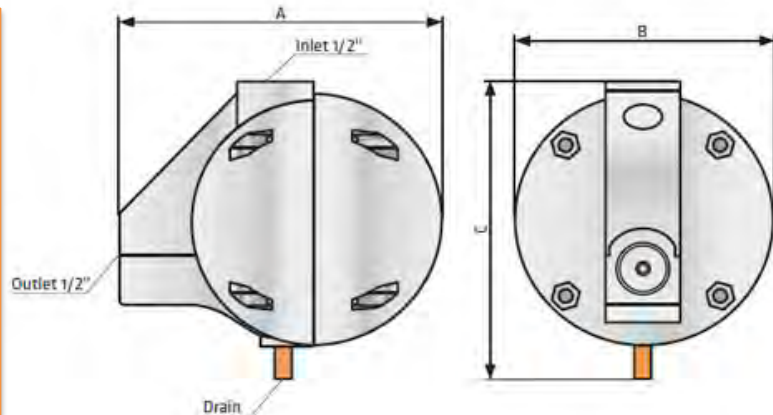

OUR OTHER PRODUCTS

- Air Compressors
- Air Dryers
- After Coolers
- Air Receiver Tank
- Air Filters
- Oil Filters
- Oil Separators



PT. SUKSES KARYA INTI PERSADA

Telp: 021-84311673 Fax: 021-84311674
 Mobile: 0813-1883-5327
 Email: marketing@skintipersada.co.id

Total Air Solution