

SK POWER SCREW AIR COMPRESSOR



PT. SUKSES KARYA INTI PERSADA

Telp.: 021-84311673

WhatsApp: 0813-1883-5327

Email: sk.intipersada@gmail.com

www.skintipersada.co.id

Belt Driven

The belt driven screw air compressor use TORIN or GU air end, both of them from Germany technique which provide high quality air, low noise and high efficiency . The belt driven screw air compressor is more elegant, easy to install, simple operation and maintain



Features of Belt Driven Screw Air Compressor

- TORIN or GU air end with high efficiency
- Double screw with low noise
- Elegant compact design and super silenced enclosure
- Fully open access door for inner parts easy service
- 100% continuous duty operation and load/no load operation
- Machine was CE and UL certificated
- Machines under ISO 9001 quality management standard system
- LCD control panel with easy use and read
- PLC control for load/no load and auto shut-off according to the air flow which save much energy
- Supply the machine with different working voltage according to customer's request, such as:
 - 380Volt, 3phase, 50hz
 - 420Volt, 3phase, 50hz
 - 380Volt, 3phase, 60hz
 - 220Volt, 3phase, 60hz etc.

Direct Driven

SK POWER Screw Air Compressor use good quality air end, which provide high-quality air, you can rely on to avoid costly downtime and production delays. Their robust design ensures your processes will function continuously even in the harshest condition such as temperature up to 55°C. Furthermore, **SK POWER** Compressors are easy to install and use, they require minimal on-site installation work and operation and maintenance are very simple.

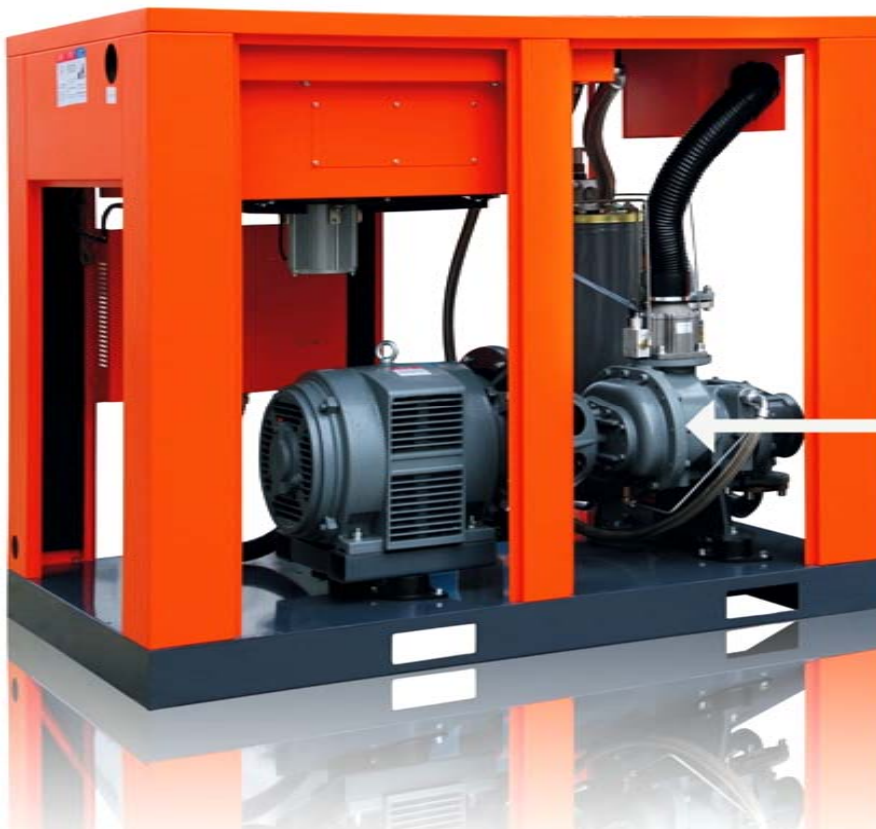

Features of Direct Coupled Screw Air Compressor

- GU Germany & Hanbell air-end with High-efficiency
- Double Screw with low noise
- Super Silenced Enclosure
- Elegant compact design
- Fully open access door to inner parts for easy service
- 100% continuous duty operation
- Load/Unload operation
- High quality CE certificate industrial electric motors.
- Easy operation of LCD control panel
- PLC control for load/unload and auto shut-off
- Easy to service "spin-on" oil filter & separators.
- High temperature, high pressure and anti-rotation shutdown
- Energy efficiency operation
- 5 micron, water-resistance air filtration material
- ISO, CE, UL certificate



Cooler Fan

Large heat dissipating surface, perfect cooling effect

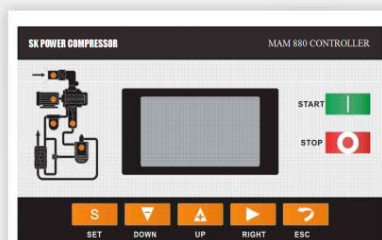

Control Panel (Chinese,English, Russian,Spanish etc. available)

Multi function display,easy to operate unattended for 24 hours at work automatically



Electricity Board (Siemens/ABB PLC)

Main electrical components use the world famous brand Schneider,Siemens etc.,professional wire input design,strong function to diagnose fault and protect automatically.



Motor (Dongguan,Qingjiang, same quality as Sullair of USA)

Using well-known brand high performance motor,protection class IP54,F class insulation,SKF load bearing,higher efficiency than similar products by 3%-5%.

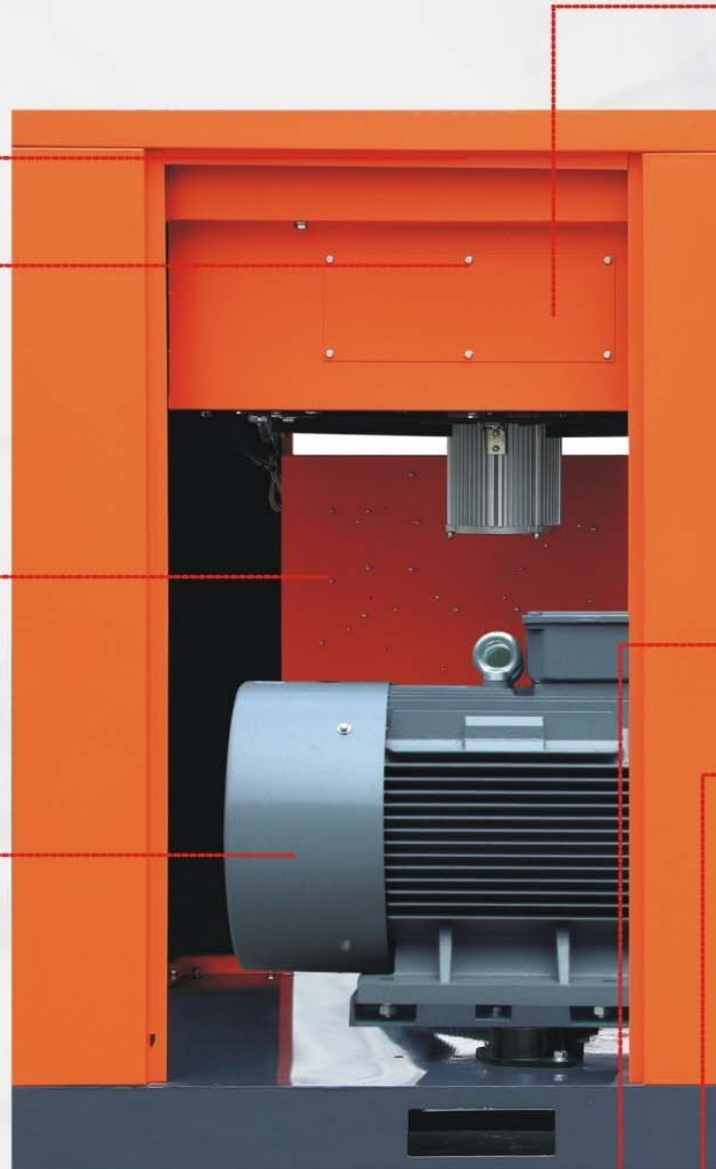

Intake Valve (Hoerbiger from Austria)

Automatically adjust based on gas consumption, low maintenance,good stability,large inlet air.



Double Screw

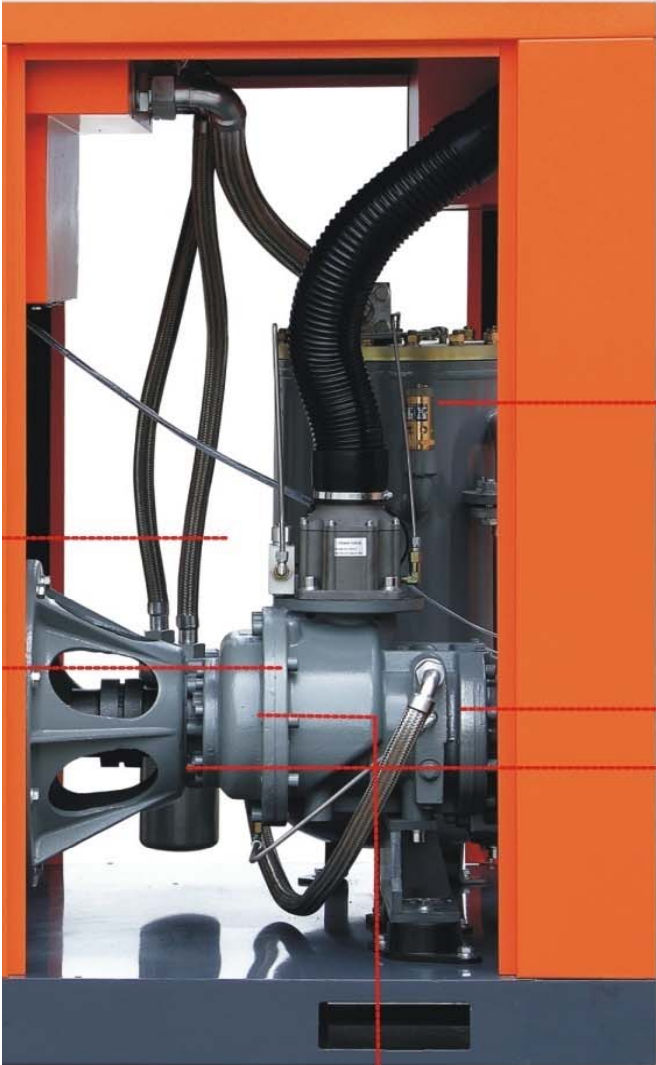

**High Efficiency Air Filter
(Germany)**

Efficient heavy air filter to ensure the quality of inlet air and safety of the air end, improved the life greatly.



**Three Grade Air and Oil Separator
(Germany)**

Built-in high efficiency air and oil separator core, to ensure the oil content of compressed air below 3PPM, fix and replace easily, good sealing, bearing high pressure.



Bearing (Sweden SKF)

Perfect stability, adapting to changeable load well, extending the life of rotor;
Lower running speed, decreasing abrasion of bearing;
Lower running temperature, decreasing load of bearing;
Higher accuracy of bearing, longer lifespan.



Air End (Torin from Germany)

Original air end from Germany and Italy, the powerful heart decides the high performance of the whole machine, to make sure bigger air capacity, higher efficiency, longer lifespan.



Oil Filter (Germany)

The efficiency is 20% higher than normal one, filter accuracy up to 9 microns, protect the air end better, and extend the service life.

Variable Speed Drive - Inverter



Cost Comparison

SK POWER Compressor VSD air compressor can change the motor RPM precisely according to the air consumption under stable discharge pressure, so air compressor so the compressor only deliver the required air, and only consume the energy of necessary compressed air. That's why the VSD type can save energy. During the whole set machine operation, the cost which by saving energy is much higher than the cost of machine itself.

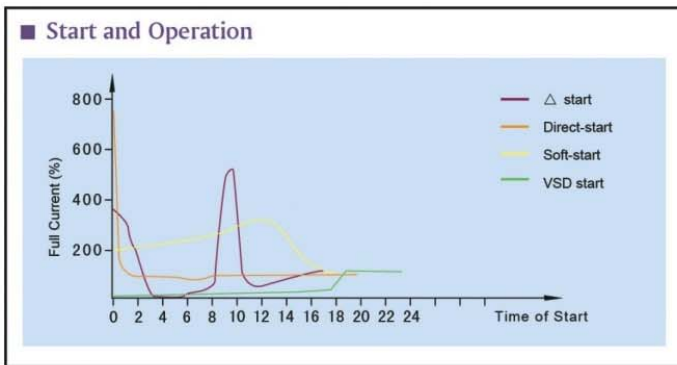

Start and Operation

The figure shows a comparison of several kinds of startup, from which we can see that VSD machine is slowly accelerating started, more stable than the soft-start, completely avoid the current peak, start frequency operation after running to the rated pressure, and adapt to the environment of lack of electricity.

Constant pressure air supply, with the balance of production

The figure shows operation between the general air compressor and VSD air compressor.

VSD machine will change the rotating speed according to air consumption, balance the air supply and air usage. Thus avoiding the machine frequent loading and unloading, making the VSD machine save more than 35% energy compared to normal compressor. Stable pressure delivery controlled the pressure zone within 0.01 Mpa – 0.02Mpa, avoid energy loss under high pressure in the normal type air compressor.

Pressure(Mpa) normal type (Energy consume for 2 bar higher)

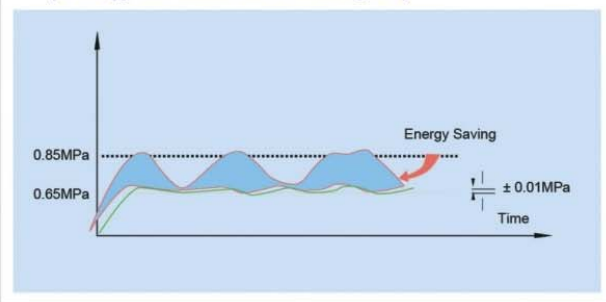

Constant pressure air supply, balance of production

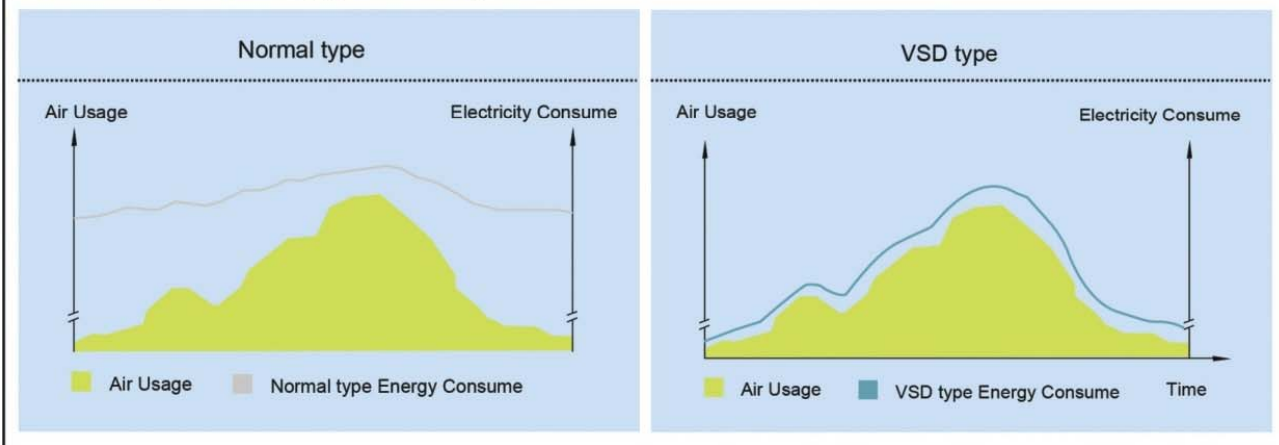

Variable Speed Drive - Inverter

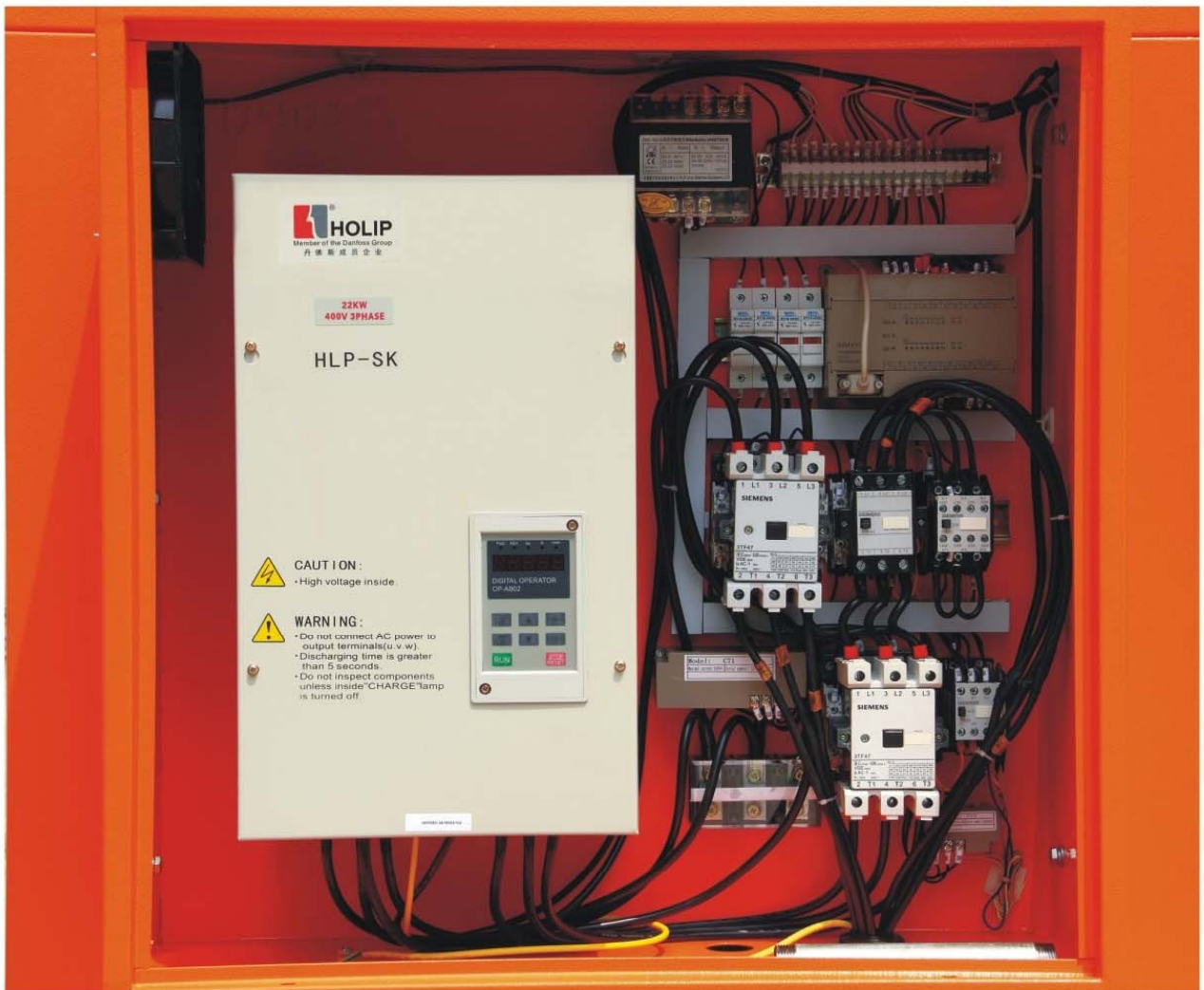

Danfoss Frequency Converter

Electricity saving result

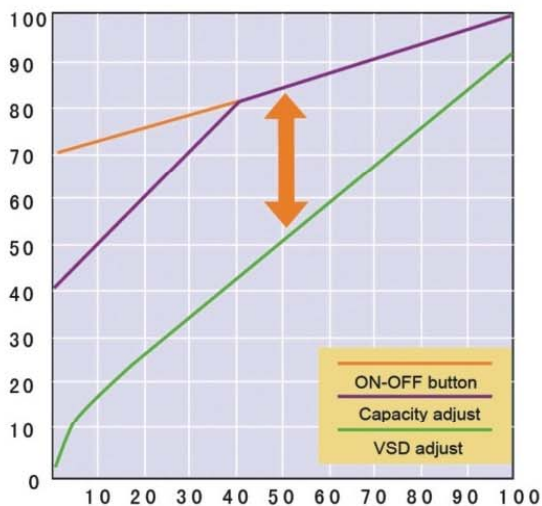

Electricity saving result

According to the research, between VSD screw air compressor and Normal screw air compressor, there are two field which can display the result of energy saving: the loss of no-loading and loss of fluctuating pressure. For example of a 55KW screw air compressor, 70% air delivery in a year, the VSD type can save about 80000Kwh energy, the cost of VSD can be take back within 2 years.

Technical Specification

► Direct Driven SK POWER Air Compressor Parameter

Model	SK-30AD	SK-50AD	SK-75AD	SK-100AD	SK-120AD	SK-150AD	SK-175AD	SK-200AD	SK-250AD	SK-300AD	SK-350AD
Free Air Delivery/Discharge Pressure (m ³ /min / Mpa)	3.8 / 0.7	6.8 / 0.7	1.0 / 0.7	13.5 / 0.7	16.1 / 0.7	21.0 / 0.7	25.2 / 0.7	28.7 / 0.7	32.0 / 0.7	36.7 / 0.7	42.0 / 0.7
	3.6 / 0.8	6.2 / 0.8	9.1 / 0.8	12.6 / 0.8	15.0 / 0.8	19.8 / 0.8	24.0 / 0.8	27.6 / 0.8	30.5 / 0.8	34.5 / 0.8	40.5 / 0.8
	3.2 / 1.0	5.6 / 1.0	8.5 / 1.0	11.2 / 1.0	13.8 / 1.0	17.0 / 1.0	21.0 / 1.0	24.6 / 1.0	27.5 / 1.0	30.2 / 1.0	38.1 / 1.0
	2.8 / 1.2	4.9 / 1.2	7.6 / 1.2	10.0 / 1.2	12.3 / 1.2	15.3 / 1.2	18.3 / 1.2	21.5 / 1.2	24.8 / 1.2	27.8 / 1.2	34.6 / 1.2
Free Air Delivery/Discharge Pressure (CFM / Psi)	134 / 102	240 / 102	253 / 102	477 / 102	569 / 102	742 / 102	890 / 102	1014 / 102	1131 / 102	1297 / 102	1484 / 102
	127 / 115	219 / 115	322 / 115	445 / 115	530 / 115	700 / 115	848 / 115	975 / 115	1078 / 115	1219 / 115	1431 / 115
	113 / 145	198 / 145	300 / 145	396 / 145	488 / 145	601 / 145	742 / 145	869 / 145	972 / 145	1067 / 145	1346 / 145
	99 / 174	173 / 175	269 / 175	353 / 175	435 / 175	541 / 175	647 / 175	760 / 175	876 / 175	982 / 175	1223 / 175
No of compression stage	Single Stage										
Ambient Temperature	-5 -- +45°C										
Cooling Model	Air - Cooling					Air/Water - Cooling			Water - Cooling		
Discharge Temperature (°C)	Ambient Temperature +15°C										
Lubricant (L)	18	30	65			90		110			
Noise Level (dB)	68±2		72±2			75±2			72±2		
Drive Method	Direct-Connected by coupling										
Electricity (V/ph/Hz)	380 / 3 / 50										
Power (KW/HP)	22/30	37/50	55/75	75/100	90/120	110/150	132/175	150/200	185/250	220/300	250/350
Starting Method	Y-Δ Starter										
Dimension L*W*H (mm)	1400	1560	1800	1900	2100	2360	2460	2560	2610	2700	2900
	900	1000	1200	1200	1400	1360	1420	1540	1640	1740	1850
	1220	1360	1600	1600	1780	1800	1800	1840	2050	2100	2150
Weight (kg)	680	1060	1880	1980	2100	2900	3500	3900	4200	4600	5000
Air Outlet Pipe Diameter (Inch/mm)	1"	1½"	2"			DN65		DN80		DN100	

► Belt-Driven SK POWER Air Compressor Parameter

Model	SK-7AB	SK-10AB	SK-15AB	SK-20AB	SK-25AB	SK-30AB	SK-40AB	SK-50AB	SK-60AB	SK-75AB	SK-100AB
Free Air Delivery/Discharge Pressure (m ³ /min/Mpa)	0.85 / 0.7	1.2 / 0.7	1.6 / 0.7	2.5 / 0.7	3.2 / 0.7	3.8 / 0.7	5.2 / 0.7	6.8 / 0.7	7.3 / 0.7	10.0 / 0.7	13.5 / 0.7
	0.75 / 0.8	1.2 / 0.8	1.5 / 0.8	2.3 / 0.8	2.9 / 0.8	3.6 / 0.8	5.0 / 0.8	6.2 / 0.8	7.0 / 0.8	9.1 / 0.8	12.6 / 0.8
		0.9 / 1.0	1.3 / 1.0	2.1 / 1.0	2.6 / 1.0	3.2 / 1.0	4.5 / 1.0	5.6 / 1.0	6.0 / 1.0	8.5 / 1.0	11.2 / 1.0
		0.7 / 1.2	1.1 / 1.2	1.9 / 1.2	2.2 / 1.2	2.8 / 1.2	3.8 / 1.2	4.9 / 1.2	5.6 / 1.2	7.6 / 1.2	10.0 / 1.2
Free Air Delivery/Discharge Pressure (CFM / Psi)	30 / 102	42 / 102	57 / 102	88 / 102	113 / 102	134 / 102	184 / 102	240 / 102	258 / 102	253 / 102	477 / 102
	27 / 115	39 / 115	53 / 115	81 / 115	102 / 115	127 / 115	177 / 115	219 / 115	247 / 115	322 / 115	445 / 115
		32 / 145	46 / 145	74 / 145	92 / 145	113 / 145	159 / 145	198 / 145	212 / 145	300 / 145	396 / 145
		25 / 174	39 / 174	67 / 174	78 / 174	99 / 174	134 / 174	173 / 175	198 / 174	269 / 175	353 / 175
No of compression stage	Single Stage										
Ambient Temperature	-5 -- +45°C										
Cooling Model	Air - Cooling										
Discharge Temperature (°C)	Ambient Temperature +15°C										
Lubricant (L)	5,4		7	8	18		25	30		65	
Noise Level (dB)	62±2	64±2			62±2			68±2		72±2	
Drive Method	Multi V-Belt										
Electricity (V/ph/Hz)	380 / 3 / 50										
Power (KW/HP)	5.5/7	7.5/10	11/15	15/20	18.5/25	22/30	30/40	37/50	45/60	55/75	75/100
Starting Method	Y-Δ Starter										
Dimension L*W*H (mm)	800	860	1100		1400			1500		1730	1820
	720	740	850		950			1000		1170	1250
	950	960	1160		1300			1420		1700	1760
Weight (kg)	128	240	400	420	600	620	680	980	1050	1600	1800
Air Outlet Pipe Diameter (Inch/mm)	3/4"				1"			1½"		2"	

Technical Specification

► Tank Mounted SK POWER Air Compressor Parameter

Model	SK-7T	SK-10T	SK-15T	SK-20T
Free Air Delivery/Discharge Pressure (m3/min / Mpa)	0.85 / 0.7	1.2 / 0.7	1.6 / 0.7	2.5 / 0.7
	0.75 / 0.8	1.2 / 0.8	1.5 / 0.8	2.3 / 0.8
		0.9 / 1.0	1.3 / 1.0	2.1 / 1.0
Free Air Delivery/Discharge Pressure (CFM / Psi)		0.7 / 1.2	1.1 / 1.2	1.9 / 1.2
	30 / 102	42 / 102	57 / 102	88 / 102
	27 / 115	39 / 115	53 / 115	81 / 115
		32 / 145	46 / 145	74 / 145
		25 / 174	39 / 174	67 / 174
No of compression stage	Single Stage			
Ambient Temperature	-5 -- +45°C			
Cooling Model	Air - Cooling			
Discharge Temperature (°C)	Ambient Temperature +15°C			
Lubricant (L)	5,4		7	8
Noise Level (dB)	53-57	63-67		
Drive Method	Multi V-Belt			
Electricity (V/ph/Hz)	380 / 3 / 50			
Power (KW/HP)	5.5/7	7.5/10	11/15	15/20
Starting Method	Y-Δ Starter			
Dimension L*W*H (mm)	1620		1620	
	720		720	
	1470		1600	
Weight (kg)	375	380	420	450
Air Tank Volume (L)	300			



► Mounted Tank - Dryer SK POWER Air Compressor Parameter

Model	SK-7TD	SK-10TD	SK-15TD	SK-20TD
Free Air Delivery/Discharge Pressure (m3/min / Mpa)	0.85 / 0.7	1.2 / 0.7	1.6 / 0.7	2.5 / 0.7
	0.75 / 0.8	1.2 / 0.8	1.5 / 0.8	2.3 / 0.8
		0.9 / 1.0	1.3 / 1.0	2.1 / 1.0
Free Air Delivery/Discharge Pressure (CFM / Psi)		0.7 / 1.2	1.1 / 1.2	1.9 / 1.2
	30 / 102	42 / 102	57 / 102	88 / 102
	27 / 115	39 / 115	53 / 115	81 / 115
		32 / 145	46 / 145	74 / 145
		25 / 174	39 / 174	67 / 174
No of compression stage	Single Stage			
Ambient Temperature	-5 -- +45°C			
Cooling Model	Air - Cooling			
Discharge Temperature (°C)	Ambient Temperature +15°C			
Lubricant (L)	5,4		7	8
Noise Level (dB)	53-57	63-67		
Drive Method	Multi V-Belt			
Electricity (V/ph/Hz)	380 / 3 / 50			
Power (KW/HP)	5.5/7	7.5/10	11/15	15/20
Starting Method	Y-Δ Starter			
Dimension L*W*H (mm)	1900		1900	
	720		720	
	1470		1600	
Weight (kg)	415	420	465	510
Air Tank Volume (L)	300			



Refrigerated Air Dryer & Compressed Air Filter



Refrigerated Compressed Air Dryer

Model	AD-10HT	AD-15HT	AD-20HT	AD-30HT	AD-50HT	AD-60HT	AD-75HT	AD-100HT	AD-120HT	AD-150HT	AD-200HT	
Air capacity (m ³ /min)	1,5	2,0	2,5	3,8	6,5	7,5	10,5	13,8	16,0	20,0	28,0	
Compressor power (KW)	0,43	0,51	0,73	0,92	1,38	1,38	1,78	2,57	2,57	2,94	4,4	
Pipe diameter	R1"	R1"	R1 1/2"	R1 1/2"	R1 1/2"	R1 1/2"	R2 1/2"	R2 1/2"	R2 1/2"	R3"	R3"	
Electricity(V/ph/Hz)	220/1/50					380/3/50						
Dimension	L	640	700	730	760	900	1020	1200	1200	1200	1400	1400
(mm)	W	380	390	420	450	500	610	600	600	600	730	730
	H	710	730	760	970	1120	990	1120	1270	1270	1350	1350
N.W.(KG)	45	50	60	80	110	123	175	202	225	315	421	

Note: 1. Ambient temperature 25 °C
 2. Compressed air temperature at inlet 40-65 °C
 3. Loss of pressure less than 0.02 MPa
 4. Dew point 2-5 °C
 5. Max. pressure 13 Bar
 6. Air inlet pressure 0.4-1.0 MPa

Air Filter

Model	Air flow (m3/min)	Connection	Dimension		Element	
			Height	Width	No.	QTY
AF-(Grade)-10	1	G 3/4"-1"	89	243	E-(Grade)12	1
AF-(Grade)-15	1.5	G 3/4"-1"	89	243	E-(Grade)16	
AF-(Grade)-24	2.4	G 1"-1 1/2"	109	310	E-(Grade)20	
AF-(Grade)-35	3.5	G 1"-1 1/2"	109	310	E-(Grade)24	
AF-(Grade)-60	6	G 1"-1 1/2"	109	450	E-(Grade)28	
AF-(Grade)-90	9	G 2"-2 1/2"	150	509	E-(Grade)32	
AF-(Grade)-120	12	G 2"-2 1/2"	150	887	E-(Grade)36	
AF-(Grade)-150	15	G 2"-2 1/2"	150	887	E-(Grade)40	
AF-(Grade)-240	24	PN16D110	275	1133	E-(Grade)44	2
AF-(Grade)-360	36	PN16D150	473	1100	E-(Grade)44	
AF-(Grade)-450	45	PN16D150	473	1265	E-(Grade)48	

Note: 1. Max. Pressure 16 Bar
 2. Filter Max. Working Temperature : 66 °C
 3. Grade (A : 3 Micron, B : 1 Micron, C : 0.01 Micron)
 4. For Large Flow Meter, Please Contact SK Power.

Mechanical Auto Drain



Dimensions

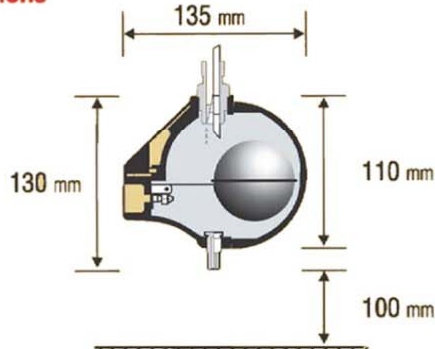

For effective removal of Condensate from:

- Filters
- Separators
- Receivers
- Ref. Dryers
- After Coolers
- Inter Coolers
- Droplegs, etc.

Working Principle

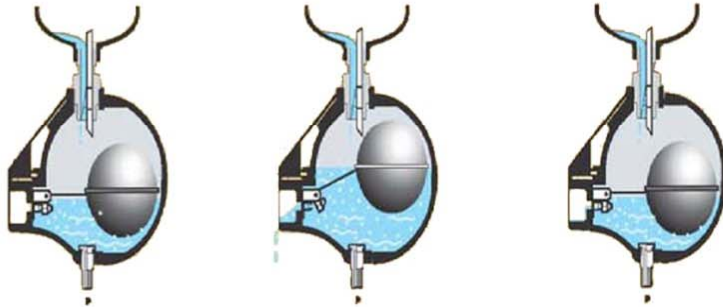

Material of Construction

- Housing : Aluminium
- Float : Stainless steel
- Lever : Stainless Steel
- Manual Drain : Brass

Technical Data	HAD-20B
Operating temperature range	Up to 100 °C
Operating pressure	20 bar
Mass	0,5 kg
Drain Capacity	400 l/hour
Inlet connection	G1/2"
Outlet connection	G1/2"
Dimension A x B x C	135 x 110 x 130 mm
Medium	Condensate (air, water, oil)

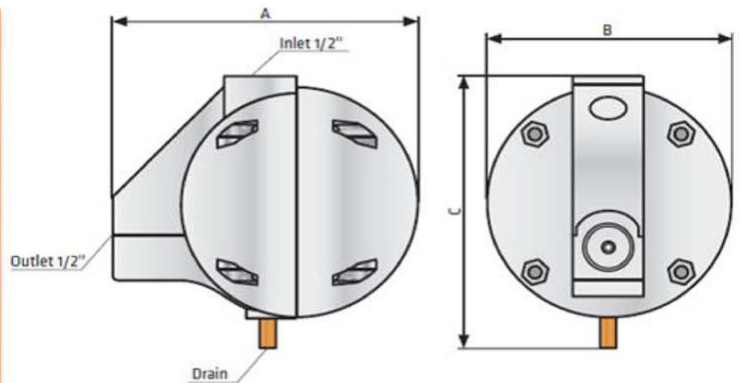

Feature :

1. Simple
2. Reliable
3. No Electric Power
4. Easy to Install
5. No Air Loss
6. Non Corrosive
7. Life Long Service
8. Mechanical Float
9. Easy Maintenance
10. Suitable For Any Industry
11. Resistance To High Temperature
12. No External Air Equaliser Required
13. Convenient 1/2" BSP(F) Connection
14. Maximum Operation Pressure 20 Bar



Good Quality, Good Price, Good Service, Good Choice



PT. SUKSES KARYA INTI PERSADA

Telp.: 021-84311673

WhatsApp: 0813-1883-5327

Email: sk.intipersada@gmail.com